

F2000 BRICK LAYOUT			
ITEM	PART ID	DESCRIPTION	QUANTITY
1	587807	BRICK-F/B, F3000, LE2, LE3, 09, 25X185X213	2
2	587808	BRICK-F/B, SIDE, LE2, 09, 25X250X260	2
3	987549	BRKT-RETAINR,BOARD LE2 BLK VHT	2
4	521060	SCREW; M6X35 HEX ZP	2
5	994258	CHANNEL-BRICK RETAINER F2000	1
6	994239	BAFFLE ASSY STL F2000	1

Amendment	Date	By

TOLERANCES :
 Decimal Places: 0 ± 0.5
 0.0 ± 0.2
 Angles Degrees: 0 ± 5°

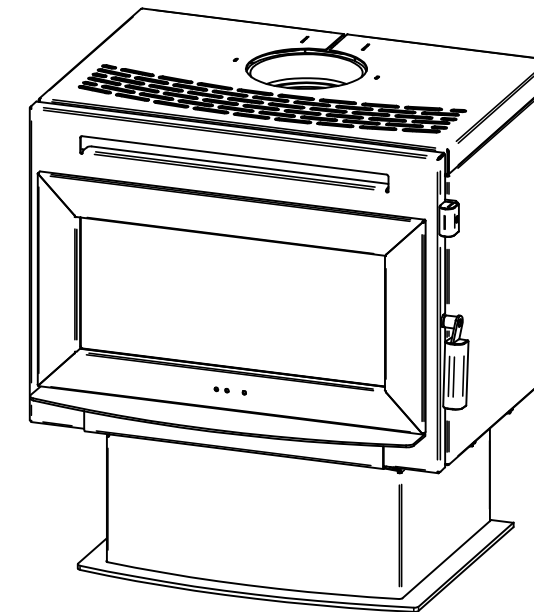
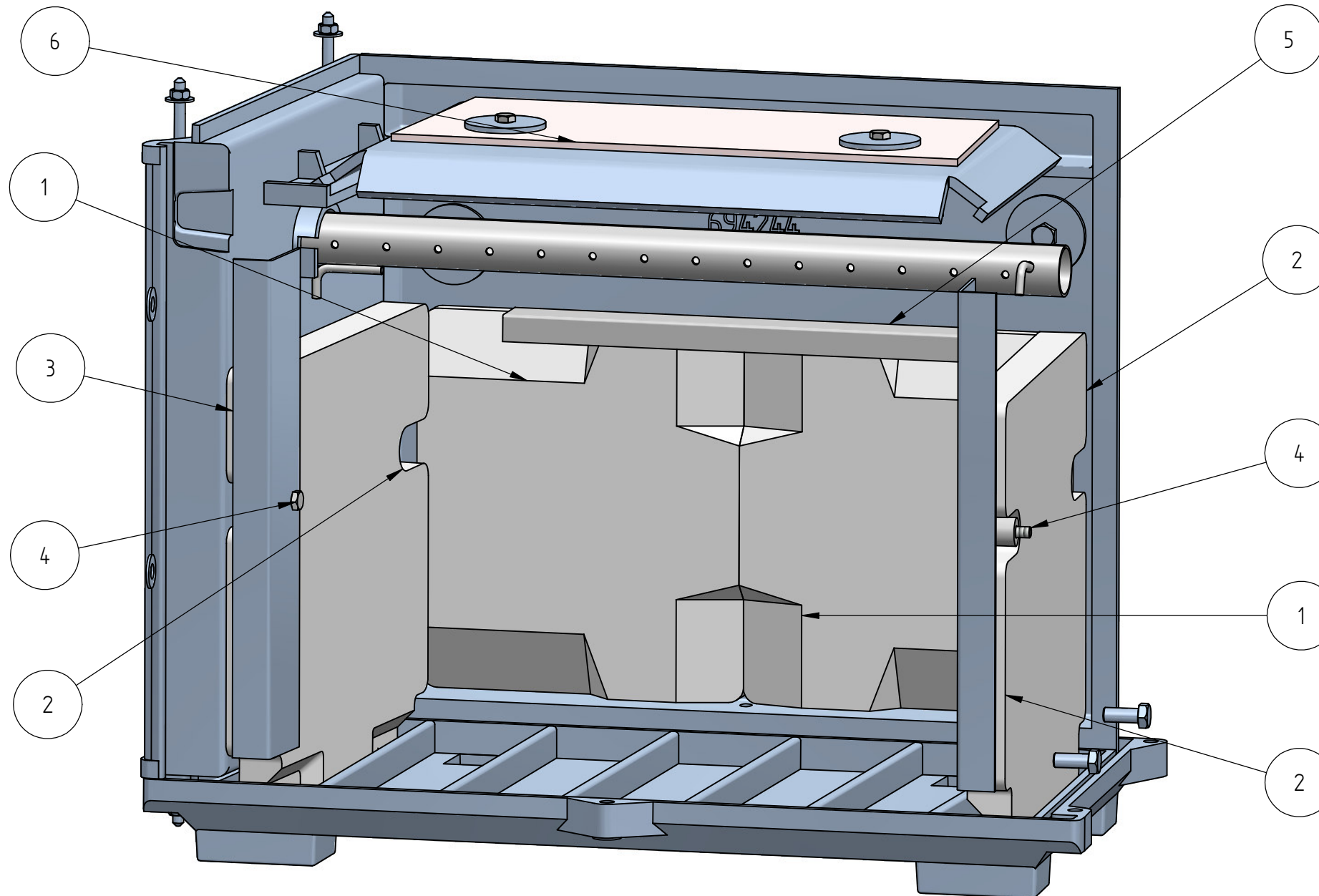

NOTES FOR INSTALLING :

- PLACE REAR BRICKS FIRST AS SHOWN IN FIREBOX.
- FIT STAINLESS STEEL CHANNEL AS SHOWN OVER REAR BRICKS.
- FIT L/H BRICK AND RETAIN WITH BRACKET (NOT PART OF KIT) WITH SCREW M6 X 35 LONG
- FIT R/H BRICK